



## Terrific Tigers

Please find today's learning tasks below.

The table below explains the tasks and you will find the resources underneath. Your child will know which challenge they usually access in each subject and which task will be appropriate for them.

Year group: 1				Date Monday 4 <sup>th</sup> May			
Challenge 1		Challenge 2		Challenge 3			
<b>English</b>	<p>Go to youtube and watch <a href="https://www.youtube.com/watch?v=2189sv8Bvy4">https://www.youtube.com/watch?v=2189sv8Bvy4</a>            This video will go through how you write instructions which we have talked about before so this should be a reminder 😊</p> <p><b><u>The Features of Instructions</u></b>            Instructions are sentences that give a commands or orders. They are bossy and tell the reader what to do. They:</p> <ul style="list-style-type: none"> <li>• are usually short, sharp sentences that do not contain much description or story language.</li> </ul> <p>Open the gate. Go down the garden path.</p> <ul style="list-style-type: none"> <li>• always contain bossy verbs that tell someone what to do or not do. These verbs are always in the present tense. They come at or near the beginning of the sentence.</li> </ul> <p>Listen for the doorbell. Do not use the doorknocker.</p> <ul style="list-style-type: none"> <li>• are addressed to the reader, as if the reader is being spoken to directly by someone.</li> </ul> <p>Go into the wood. Watch out for the wolves.</p> <ul style="list-style-type: none"> <li>• often 'list' things to do or avoid doing.</li> </ul> <p>Walk through the wood, jump over the wall and then climb into the tree.</p> <ul style="list-style-type: none"> <li>• can be numbered or have bullet points.</li> </ul>						
	<p>Today we are going to look at a set of instructions and highlight the word that is the bossy verb – which word tells you what to do?            Can you highlight the words on the instructions below and then follow</p>	<p>Today we are going to highlight the time connectives in one colour (the lady in the video calls them time conjunctions) and the imperative verbs (bossy verbs) in another, just like in the video.            Look at the instructions below and print if you can. If not tell an adult which words are</p>	<p>Today we are going to highlight the time connectives in one colour (the lady in the video calls them time conjunctions) and the imperative verbs (bossy verbs) in another, just like in the video.            Look at the instructions below and print if you can. If not tell an adult which words</p>				

	<p>the instructions to make an aeroplane.</p>	<p>time connectives and which words are bossy verbs.</p> <p>Choose one colour for time connectives and another colour for bossy verbs.</p> <p>Next we are going to see if you can make a paper aeroplane. Follow the instructions below – does it work?</p>	<p>are time connectives and which words are bossy verbs.</p> <p>Choose one colour for time connectives and another colour for bossy verbs.</p> <p>Can you make the paper aeroplane using the instructions?</p> <p>Can you fill in the What you need box? Now can you add a top tip box? What would you tell someone else if they were using these instructions? Would you tell them to take care or make sure they do something, or...?</p>
<p><b>Maths</b></p>	<p>This week we are looking at position and direction. We are going to start with turns, so why not practise first with your adult making a whole turn, half a turn, a quarter turn and a three quarter turn. Remember to think about turning left or right. You could always wear a bracelet or wristband to remind you which is which!</p> <p>Then go to <a href="#">Education city</a>, log in and complete Land Ahoy!</p>		
	<p>Complete the sheet below or if you cannot print, show an adult what the object would look like after the turn.</p>	<p>Complete the sheet below or if you cannot print, draw what the shape would look like after the turn.</p>	<p>Complete the sheet below or draw what the shape will look like after the turn.</p> <p>Can you complete the challenge? Is Che correct?</p> <p>You might find it helpful to make the shape in paper and practise turning it to see if Che has worked it out correctly.</p>
<p><b>Phonics</b></p>	<p>Search on you tube set 2 speed sounds -watch the read write inc speed sound video from 9.30am or there may be the one on from the day before!</p>	<p>Search on you tube set 3 speed sounds -watch the read write inc speed sound video from 9.30am or there may be the one on from the day before!</p>	<p>Search on youtube for Spelling Patterns   "oo", "ew", "u", "ue", "u_e"   My Growing Brain</p> <p><a href="https://www.youtube.com/watch?v=jNpqXXClrAA">https://www.youtube.com/watch?v=jNpqXXClrAA</a></p>

	 <p><b>Set 2 Speed Sounds</b></p> <p>Can your parent/carer make a list of the words the lady reads out...afterwards they could read one out at a time and you can have a go at spelling them!</p>	 <p><b>Set 3 Speed Sounds</b></p> <p>Can your parent/carer make a list of the words the lady reads out...afterwards they could read one out at a time and you can have a go at spelling them!</p>	 <p>Watch again with no sound and see if you can say the words by yourself.</p>
<b>Reading</b>	<p>Log on to Oxford Owls and choose a free e book to read. If you like you can choose one from the same colour book band as your reading book by selecting 'level'.</p>		
<b>Other</b>	<p>This week we are learning about <b>VE Day</b>.          Watch the powerpoint and find out about VE day which we celebrate every year on the 8<sup>th</sup> May and this year it is the 75<sup>th</sup> anniversary. Read the facts below.</p> <div data-bbox="936 817 1473 1018" data-label="Image"> </div> <p>Can you design a medal for the soldiers who fought in the war? What colour will your ribbon be? What will you draw in the middle?          Use the template below or draw your own.</p>		

Unless otherwise specified , please complete the tasks in either your home learning book or on a word document.

## English Challenge 1

### Instructions

1. Get a piece of paper.
2. Fold the paper in half lengthways.
3. Put the top two corners down into the middle.
4. Fold the sides in lengthways and make a crease again.
5. Fold back each wing and make a crease.
6. Hold it in your hand and throw it forwards.

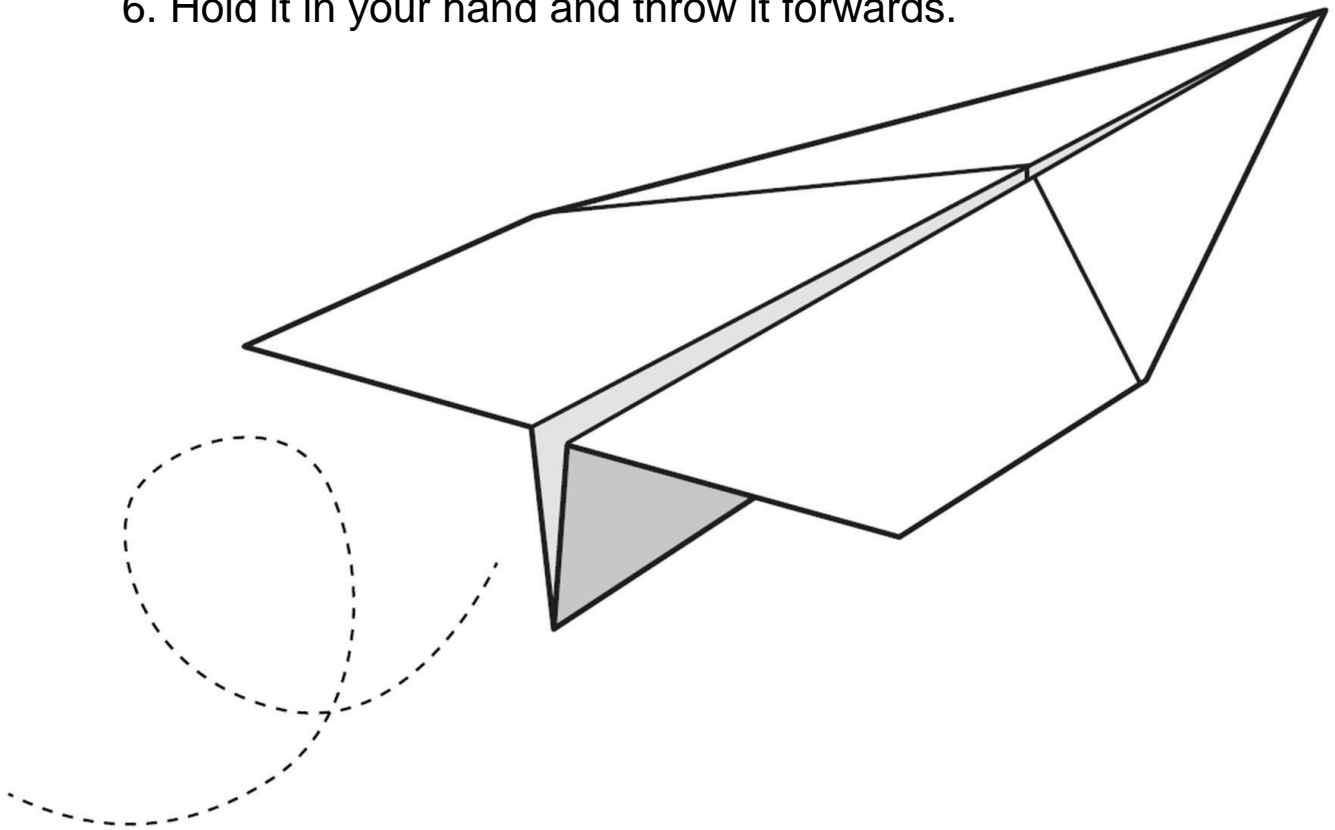

## English Challenge 2

Choose 2 different colours. Highlight the time connectives in one colour. Highlight the bossy verbs in a different colour.

### Instructions

1. First get a piece of paper.
2. Then carefully fold the paper in half lengthways.
3. Now unfold it again and place the top two corners down into the middle and fold firmly.
4. Next fold the sides in lengthways and make a crease again.
5. After fold back each wing and make a crease.
6. Finally hold it in your hand carefully and throw it forwards.

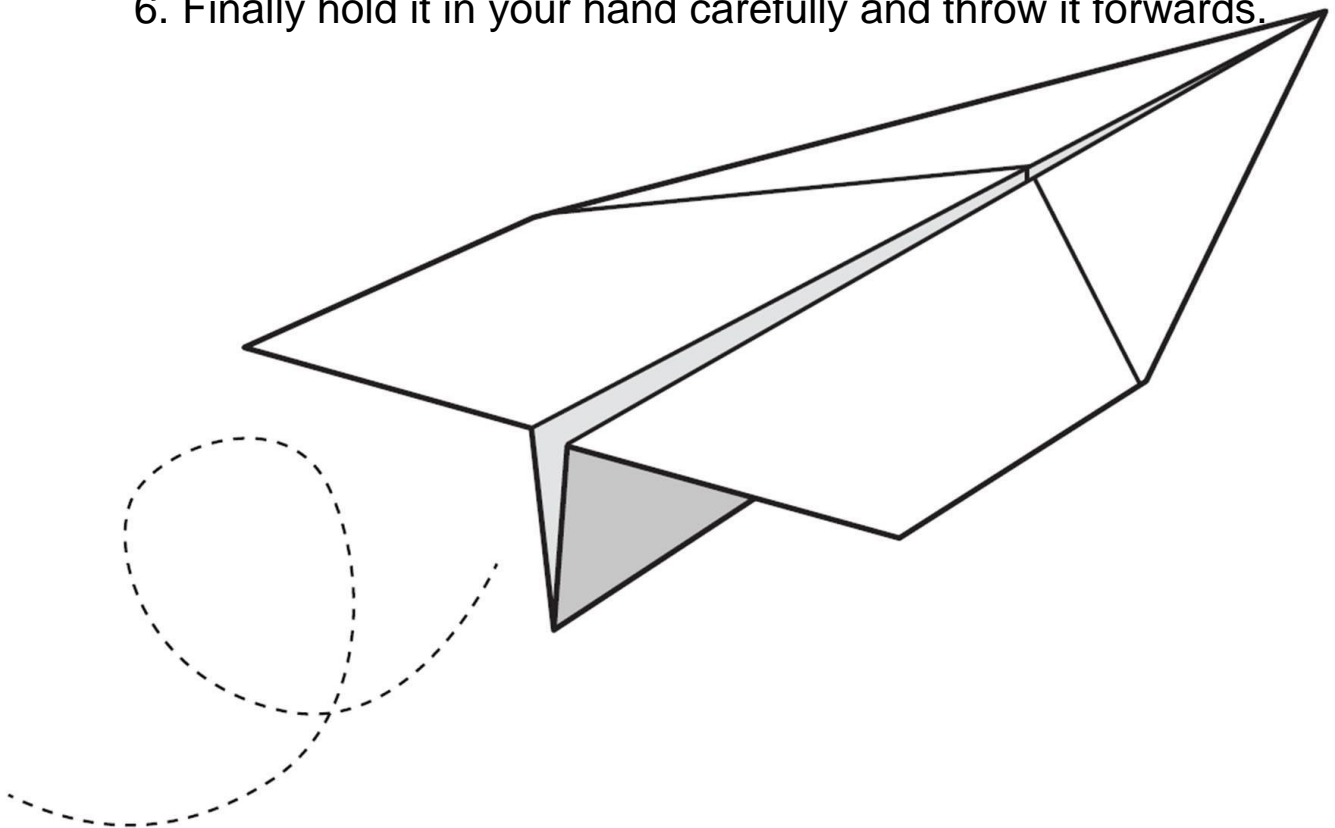

### English Challenge 3

Choose 2 different colours. Highlight the time connectives in one colour. Highlight the bossy verbs in a different colour.

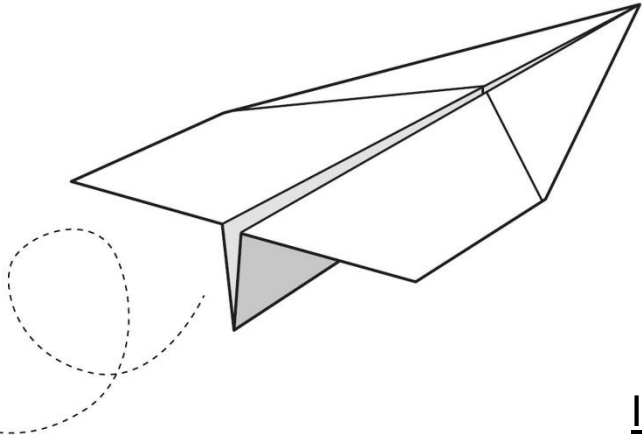

What you need:

---

---

---

---

---

### Instructions

1. First get a piece of paper.
2. Then carefully fold the paper in half lengthways.
3. Now unfold it again and place the top two corners down into the middle and fold firmly.
4. Next fold the sides in lengthways and make a crease again.
5. After fold back each wing and make a crease.
6. Finally hold it in your hand carefully and throw it forwards.









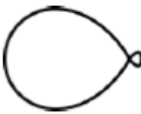

Top tip:

---

---



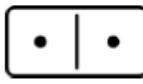

---

## Challenge 1 Maths

Object	Turn	Object after turn
	Full turn	 
	Half turn	 
	Quarter turn	 
	Three-quarter turn	 



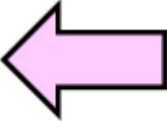

## Challenge 2 Maths

Draw what the shapes will look like after the turns.

Shape	Turn	Shape after turn
	Full turn	
	Half turn	
	Quarter turn	
	Three-quarter turn	
	Half turn	



## Challenge 3 Maths

Object	Turn	Object after turn
	Full turn	
	Half turn	
	Quarter turn	
	Three-quarter turn	

## Challenge!

You might want to make this shape in paper to help you!



The turn that has been made is a half turn.

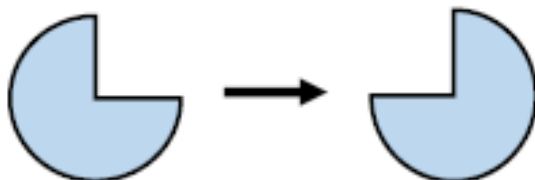

Is Che correct?  
Explain how you know.

# VE Day

## What is VE Day?

VE Day - or 'Victory in Europe Day' - marks the day towards the end of World War Two (WW2) when fighting Nazi Germany came to an end.

On 8 May 1945, Prime Minister Winston Churchill made an announcement on the radio at 3pm that the war in Europe had come to an end, following Germany's surrender the day before.

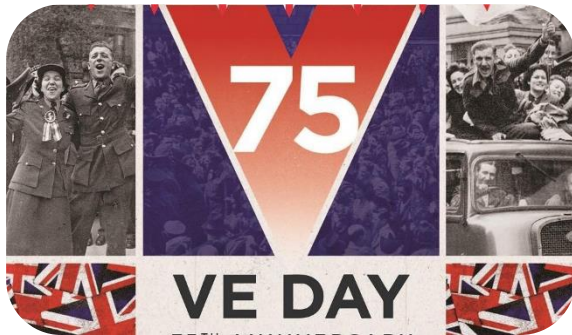

## Why is VE day so important this year?

The 8th of May this year commemorates 75 years since the first VE day in 1945.

This is why many celebrations were planned this year.

It is important to remember the sacrifices people made in World War Two.

## What can I do to celebrate VE Day?

Why not start by watching a short video explaining what VE day is about.

<https://www.bbc.co.uk/teach/class-clips-video/history-ks2-ve-day/z7xtmfr>



Please send a photograph of your work to your teacher to share on twitter.



